

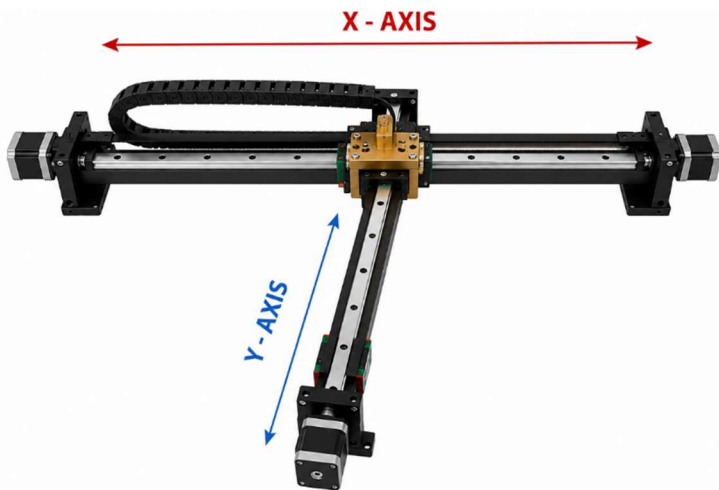

The Infitek Laser 3020 CO₂ Laser Cutting & Engraving Machine is a compact and efficient desktop laser system designed for precision engraving and cutting applications. With a 300mm × 200mm working area, it is an ideal solution for small businesses, educational institutions, hobbyists, and customized product manufacturers seeking professional-quality results in a space-saving design. Built with Infitek Laser's commitment to reliability and performance, the 3020 model delivers accurate engraving, clean cutting edges, and consistent operation across a variety of non-metal materials. Its compact footprint makes it easy to install in offices, workshops, and educational labs while maintaining excellent productivity.



RIGHT VIEW



FRONT VIEW



LEFT VIEW

D-410, FOURTH FLOOR, SP, SQUARE, NR RAMOL POLICE STATION, AHMEDABAD - 382449.

E-MAIL: sales@infiteklaser.com web: www.infiteklaser.com

Contact: +91 8140300050, 8511534914

SPECIFICATION	MODEL
	Infitek_3020
CUTING AREA (X - Y)	300mm X 200mm
LASER POWER	40W / 60W
LASER SOURCE	SEALED GLASS CO2 LASER TUBE
TRAVELING PEED	600 mm/s
REPOSITION ACCURACY	0.02 mm
X- Y MOVEMENT MECHANISM	BELT TRASMISSION
DRIVING SYSTEM	STEPPER MOTOR / SERVO MOTOR
OPREATING SYSTEM	WINDOW 7/8/10 (32/64 BIT)
Z-AXIS MOVEMENT	UPTO 180 mm (AUTOMATIC) (OPTIONAL)
MINIMUM LATTER SIZE	1.0 mm (ENGLISH LETTER)
POWER ADJUSTMENT	1 TO 100 %
COMPUTER INTERFACE	USB/UDISK/ETHERNET
COMPATIBLE SOFTWARE	AUTOCAD / CORELDRAW / PHOTOSHOP / TAJIMA
SUPPORTED FILE FORMAT	DXF/PLT/BMP/DWG/AI/JPG/GIF/HPGL
SUPPORTED MATERIAL	ACRYLIC, MDF, LEATHER, STONE
WORKING VOLTAGE	SINGLE PHASE 220-230V/ 50Hz-60Hz
OPERATING ENVIRONMENT	45 C, HUMIDITY 5% - 80%
MEMORY BUFFER	128 MB
FUME EXTRACCTION SYSTEM	CONNECTION OUTOUT 6" DIAMETER INCLUDING EXTERNAL EXHAUST STSTEM WITH MINIMUM FLOW RATE 1200m3/h (CFM 706 Ft./h)
POWER CONSUMPTION	2KW

❖ ACCESSORIES

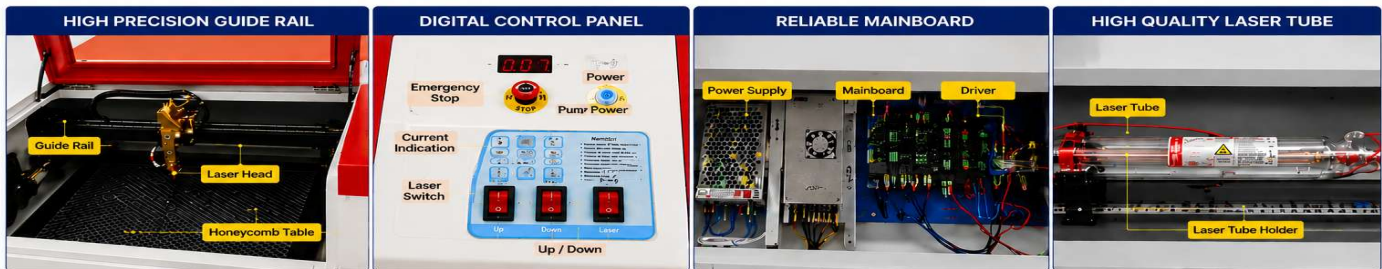

ACCESSORIES, SUPPORTING COMPONENTS & MATERIAL SAMPLES							
<p>LASER TUBE High quality CO₂ laser tube with long service life and stable output power.</p> 	<p>HONEYCOMB TABLE Thickened honeycomb working table for better ventilation and flat workpiece support.</p> 	<p>INDUSTRIAL WATER CHILLER CW-3000/CW-5000 industrial water chiller for stable cooling performance.</p> 	<p>FOCUS LENS & MIRRORS High quality USA II-VI lenses and mirrors for better cutting and engraving result.</p> 	<p>AIR ASSIST PUMP Air assist pump provides clean air to protect the lens and improve cutting performance.</p> 	<p>WATER PUMP High lift water pump ensures smooth water circulation for cooling system.</p> 	<p>CONTROL WIRING High quality wiring and connectors for stable and safe operation.</p> 	<p>EXHAUST FAN Powerful exhaust fan for smoke removal and proper ventilation.</p> 
<p>MATERIAL SAMPLES (MDF)</p> 	<p>MATERIAL SAMPLES (ACRYLIC)</p> 	<p>MATERIAL SAMPLES (LEATHER)</p> 	<p>MATERIAL SAMPLES (GLASS)</p> 				

* Material samples are examples of common materials that can be engraved or cut using this machine.

D-410, FOURTH FLOOR, SP, SQUARE, NR RAMOL POLICE STATION, AHMEDABAD - 382449.

E-MAIL: sales@infiteklaser.com web: www.infiteklaser.com

Contact: +91 8140300050, 8511534914